

G-Series 60" Raised Griddle/Broiler Gas Range

Project _____
 Item _____
 Quantity _____
 CSI Section 11400
 Approved _____
 Date _____

Models

- G60-6R24RR • G60-6R24RS • G60-6R24SS



Model G60-6R24RR

Standard Features

- Large 27" (686mm) work top surface
- Stainless steel front and sides
- Stainless steel 5" (127mm) plate rail
- Stainless steel backguard, w/ removable stainless steel shelf
- 12" (305mm) section stamped drip trays w/ dimpled bottom
- 6" (152mm) adj. stainless steel legs
- Large phenolic knobs
- Gas regulator
- Easy to access oven pilot
- Reinforced chassis
- Ergonomic split cast-iron top ring grates
- 33,000 BTU/9.67 kW 2-piece cast-iron Starfire® open top burner
- 24" (610mm) raised griddle/broiler section on right side only W/ 3 cast-iron burners each rated 11,000 BTU/3.22 kW, w/ one manual hi/lo valve per burner
- Two broiler rack settings at 3 3/4" (95mm) and 2 1/2" (64mm)
- 5/8" (15mm) thick steel griddle plate w/manual hi/lo valve control, 23" (584mm) working depth surface, standard on right, optional on left
- 4-1/4" (108mm) wide grease trough
- 38,000 BTU/ 11.13 kW cast-iron "H" style oven burner
- Snap-Action modulating oven thermostat low to 500° F
- Nickel-plated oven rack and 3-position

- removable oven rack guide
- Large porcelain oven interior, standard oven fits standard sheet pans in both directions
- Square-cornered door design with strong, "keep-cool" oven door handle
- Open storage in lieu of oven, (suffix S)

Options & Accessories

- Hot top 12" (305mm) plate in lieu of two open burners, manual valve controlled w/18,000 BTU/5.27 kW cast-iron "H" burner standard on left side
- Low-profile 9-3/8" (238mm) backguard stainless steel front and sides
- Additional oven racks
- Four 6" (152mm) levelling swivel casters w/front locking
- Flanged deck mount legs
- Celsius temperature dials

Specifications

Gas restaurant series range with large capacity standard oven. 59-1/16" (1500mm) wide.

27" (686mm) deep work top surfaces.

Stainless steel front, sides and 5" wide front rail.

6" (152mm) legs with adjustable feet.

Six Starfire® 2-piece, 33,000 BTU/9.67 kW (natural gas), cast-iron open burners set in split cast-iron ergonomic grates.

24" (610mm) raised griddle/broiler section on right side only with 3 cast-iron burners each rated a 11,000 BTU/3.22 kW.

Optional hot-top with cast-iron "H" style burners, 18,000 BTU/5.27 kW (natural gas), in lieu of open burners.

Porcelain oven interior.

Heavy cast-iron "H" oven burner rated 38,000 BTU/11.13 kW (natural gas)

Oven controlled by even bake, fast recovery snap-action modulating oven thermostat.

Available with storage base in lieu of standard oven.

NOTE: Use only Garland certified casters and approved restraining devices.



G-Series 60" Raised Griddle/Broiler Gas Range

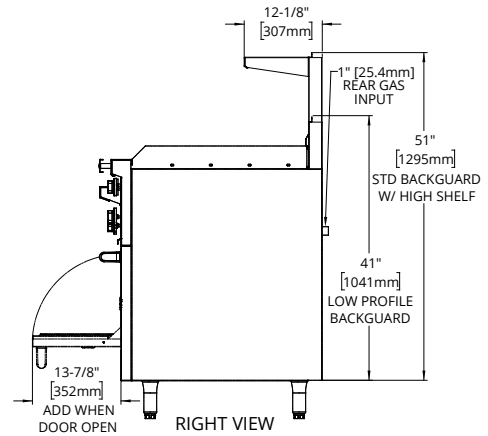
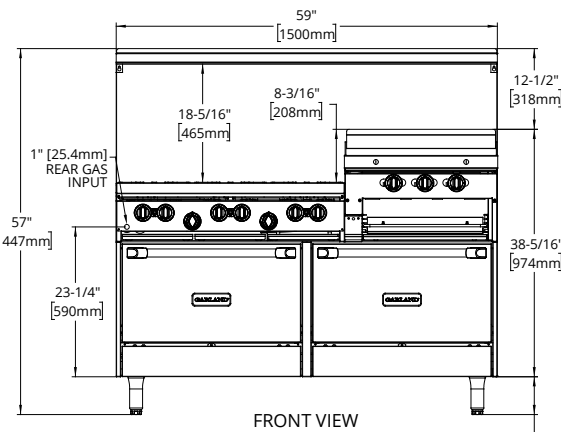
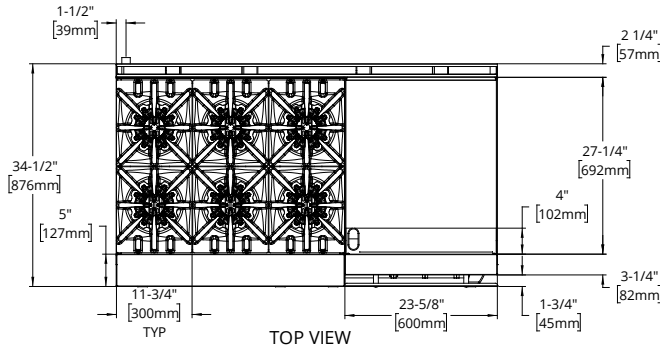

Gas input ratings shown for installations up to 2000 ft., (610m) above sea level. Please specify altitudes over 2000 ft.

This product is not approved for residential use.

Note: Installation clearance reductions are applicable only where local codes permit.

Model Number	Description	Total BTU/Hr Natural Gas	Shipping Information		
			Lbs.	Kg	Cu Ft
G60-6R24SS	6 Open Burners, 24" Raised Griddle/Broiler w/ Double Storage Base	231,000	662	300	81
G60-6R24RR	6 Open Burners, 24" Raised Griddle/Broiler w/ (2) Standard Ovens	307,000	828	376	81
G60-6R24RS	6 Open Burners, 24" Raised Griddle/Broiler w/ (1) Standard Ovens & Storage Base	269,000	787	357	81

Width In (mm)	Depth In (mm)	Height w/shelf In (mm)	Oven Interior-in (mm)			Combustible Wall Clearance-In (mm)		Entry Clearances In (mm)		Manifold Operating Pressure	
			Height	Depth	Width	Sides	Rear	Crated	Uncrated	Natural	Propane
59-1/16 (1500)	34-1/2 (876)	57 (1448)	13 (330)	26 (660)	26-1/4 (667)	14 (356)	6 (152)	37 (940)	36-1/2 (927)	4.5" WC 11 mbar	10.0" WC 25 mbar

Burner Ratings (BTU/Hr/kW)			
Gas Type	Open Top	Hot Top	Standard Oven
Natural	33,000/9.67	18,000/5.27	38,000/11.13
Propane	30,000/8.79	18,000/5.27	32,000/9.38

Garland reserves the right to make changes to the design or specifications without prior notice.

Garland Commercial Ranges Ltd.
1177 Kamato Road,
Mississauga, Ontario
L4W 1X4 CANADA

General Inquires 1-905-624-0260
USA Sales, Parts and Service 1-800-424-2411
Canadian Sales 1-888-442-7526
Canada or USA Parts/Service 1-800-427-6668

www.garland-group.com
8071A
01/26

